



# Motson<sup>®</sup>

FASTENERS

Nothing But The Best

## MOTSON FASTENERS

### Know Us

With the new waves of architectural styles and trends, machine screw has occupied the nook and corner of every industry set up. We, MOTSON FASTENERS, started our business journey in 2014. For our unique and high quality products, we have become one of the noted manufacturers and suppliers in the industry. We offer our clients high quality Stainless Steel Machine Screw in different brands like MF with product range of CSK, PAN, OVEAL HEAD, BUTTON HEAD, ALLEN CSK & ETC. with PHILLIPS & SLOTTED HEAD in every products.

Being a quality centric organization, offering the best quality products to the clients is our only concern. To assure full guarantee and client satisfaction, we have employed experienced quality check inspectors in our high tech quality assurance unit. They conduct stringent quality tests in each and every stage of production. For our international standard products, we have achieved the honor of ISO 9001:2008 certification. Also, we are backed by a modern infrastructure, which is equipped with all the latest and high tech facilities.

### Products We Offer

We offer a wide range of high quality brands of machine screws, self tapping screws, self drilling screws and other special type of screws in stainless steel with brand named ,MOTSON FASTENERS to our customers. We use quality material, equipment and latest techniques in the production processes. We also have quality check inspectors, who follow stringent quality control measures during the manufacturing process. Various materials we use are 202,304,316 grades wire and etc. We are offering following to our clients:

- Self Tapping Screws
- Machine Screw
- CSK Philips Self Drilling Screw
- PAN Philips Self Drilling Screw
- Truss Head Screw
- Button Head Screw
- Cheese Head Screw
- CSK Phillips Head Screw
- PAN Phillips Head Screw
- Chipboard Screw
- CSK Slotted Screw
- Drywall Screw

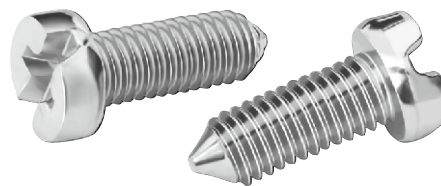

### Quality Confrontation

“High quality” is an indispensable element of our working system. For our international standard product range, we have achieved the ISO 9001:2008 certification. We have a separate quality assurance unit fully equipped with high tech machineries. This unit is administered by skilled and professional quality inspectors, who check the products during every stage of production. Moreover, we have also developed a renowned vendor base to source high quality material. The final delivery process of our products to our clients is also carried out under strict vigilance of our quality inspectors. They check the quality of the end products on the basis of following parameters:

## MOTSON FASTENERS

### PAN PHILIPS SELF TAPPING SCREW (DIN-7981)

**Diameter Range** : 2.9# To 6.3#  
**Length** : 6.5MM to 100MM  
**Threads Type** : (AB) Type AND (B) Type  
**Material** : Stainless Steel and also as per customer requirements  
**Standards** : DIN, ISO

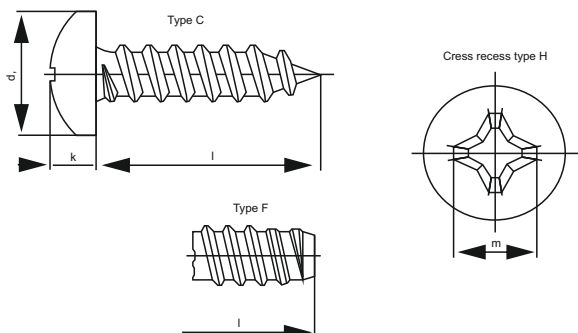

Thred size	ST 2.9	ST 3.5	ST 4.2	ST 4.8	ST 5.5	ST 6.3
No	#4	#6	#8	#10	#12	#14
Pitch	1.1	1.3	1.4	1.6	1.8	1.8
max	5.6	6.9	8.2	9.5	10.8	12.5
min	5.3	6.54	7.84	9.14	10.37	12.07
max	2.2	2.6	3.05	3.55	3.95	4.55
min	1.95	2.35	2.75	3.25	3.65	4.25
Cross recess No.	1	2		3		
M~	4.2	3	5	4.6	6.5	7.1
Penetration min Typw H	1.4	1.35	2.26	1.8	2.49	3
depth max	2.03	1.8	2.87	2.46	3.15	3.66

\*All Dimensions in mm

### CSK PHILIPS SELF TAPPING SCREW (DIN-7982)

**Diameter Range** : 2.9# To 6.3#  
**Length** : 6.5MM to 100MM  
**Threads Type** : (AB) Type AND (B) Type  
**Material** : Stainless Steel and also as per customer requirements  
**Standards**: DIN, ISO

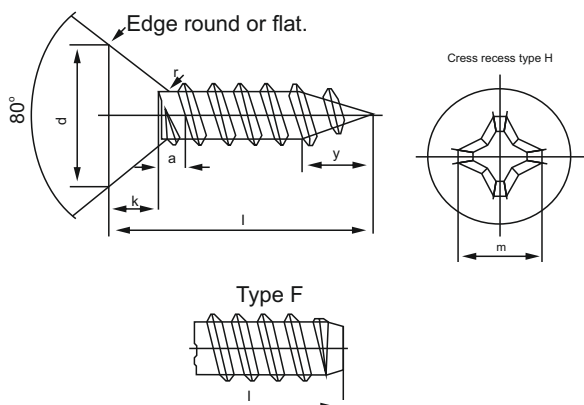

Thred size d	ST 2.9	ST 3.5	ST 4.2	ST 4.8	ST 5.5	ST 6.3
No	#4	#6	#8	#10	#12	#14
Pitch	1.1	1.3	1.4	1.6	1.8	1.8
max	5.5	6.8	8.1	9.5	10.8	12.4
min	5.2	6.44	7.74	9.14	10.37	11.97
k	1.7	2.1	2.5	3	3.4	3.8
Cross recess No.	1	2		3		
M~	3	4.2	4.7	5.1	6.8	7.1
Penetration min Typw H	1.4	1.62	2.11	2.59	2.95	3.33
depth max	1.7	2.12	2.62	3.1	3.53	3.91

\*All Dimensions in mm

### OVAL HEAD SELF TAPPING SCREW (DIN-7983)

**Diameter Range** : 2.9# To 6.3#  
**Length** : 6.5MM to 100MM  
**Threads Type** : (AB) Type AND (B) Type  
**Material** : Stainless Steel and also as per customer requirements  
**Standards**: DIN, ISO



## MOTSON FASTENERS

### CSK PHILIPS SELF DRILLING SCREW (DIN-7504 O)



**Diameter Range** : 2.9# To 6.3#  
**Length** : 9.5MM to 100MM  
**Threads Type** : (AB) Type  
**Material** : Stainless Steel and also as per customer requirements  
**Standards** : DIN, ISO

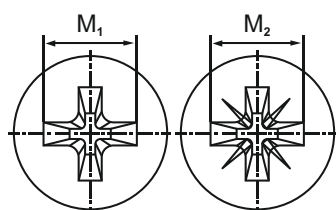
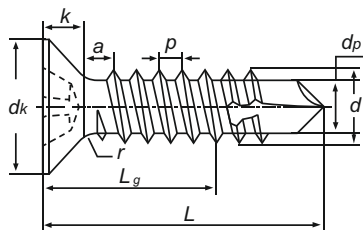

Form H

Form Z

THREAD SIZE		ST2.9 (4#)	ST3.5 (6#)	ST4.2 (8#)	ST4.8 (10#)	ST5.5 (12#)	ST6.3 (14#)
P	pitch	1.10	1.30	1.40	1.60	1.80	1.80
a	max	1.10	1.30	1.40	1.60	1.80	1.80
dk	max	5.50	7.30	8.40	9.30	10.30	11.30
	min	5.20	6.90	8.00	8.90	9.90	10.90
k	max	1.70	2.35	2.60	2.80	3.00	3.15
r	max	1.20	1.40	1.60	2.00	2.20	2.40
SOCKET NO.		1	2	2	2	3	3
M1		3.20	4.40	4.60	5.20	6.60	6.80
M2		3.20	4.30	4.60	5.10	6.50	6.80
dp		2.30	2.80	3.60	4.10	4.80	5.80
drilling range(thickness)		0.7~1.9	0.7~2.25	1.75~3.00	1.75~4.4	1.75~5.25	2~6
Lg (min.)		-	-	-	-	-	-

### PAN PHILIPS SELF DRILLING SCREW (DIN-7504 M)



**Diameter Range** : 2.9# To 6.3#  
**Length** : 9.5MM to 100MM  
**Threads Type** : (AB) Type  
**Material** : Stainless Steel and also as per customer requirements  
**Standards** : DIN, ISO

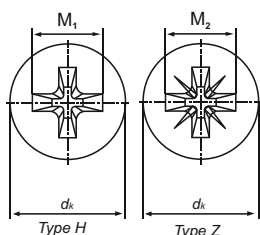
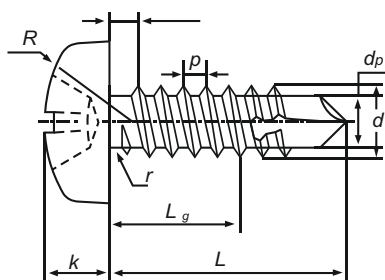

Type H

Type Z

THREAD SIZE		ST2.9 (4#)	ST3.5 (6#)	ST4.2 (8#)	ST4.8 (10#)	ST5.5 (12#)	ST6.3 (14#)
P	pitch	1.10	1.30	1.40	1.60	1.80	1.80
a	max	1.10	1.30	1.40	1.60	1.80	1.80
dk	max	5.60	7.0	8.0	9.50	11.0	12.0
	min	5.30	6.64	7.64	9.14	10.57	11.57
k	max	2.40	2.60	3.10	3.70	4.0	4.60
	min	2.15	2.35	2.80	3.40	3.70	4.30
r	min	0.10	0.10	0.20	0.20	0.25	0.25
R	~~	5.0	6.0	6.50	0.80	9.0	10.0
dp		2.30	2.80	3.60	4.10	4.80	5.80
drilling range(thickness)		0.7~1.9	0.7~2.25	1.75~3.00	1.75~4.4	1.75~5.25	2~6
SOCKET NO.		1	2	2	2	3	3
M1		3.0	3.90	4.40	4.90	6.40	6.90
M2		3.0	4.0	4.40	4.80	6.20	6.80
Lg (min.)		-	-	-	-	-	-

## MOTSON FASTENERS



### SS DRYWALL SCREW

**Diameter Range** : 2.9# To 6.3#  
**Length** : 9.5 To 100MM  
**Threads Type** : (AB) Type  
**Material** : Stainless Steel and also as per customer requirements  
 Standards: DIN, ISO

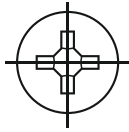

Thred size d	ST 2.9	ST 3.5	ST 4.2	ST 4.8	ST 5.5	ST 6.3
No	#4	#6	#8	#10	#12	#14
Pitch	1.1	1.3	1.4	1.6	1.8	1.8
max	5.5	6.8	8.1	9.5	10.8	12.4
min	5.2	6.44	7.74	9.14	10.37	11.97
k	1.7	2.1	2.5	3	3.4	3.8
Cross recess No.	1	2			3	
M~	3	4.2	4.7	5.1	6.8	7.1
Penetration min Typw H depth	1.4	1.62	2.11	2.59	2.95	3.33
max	1.7	2.12	2.62	3.1	3.53	3.91

\*All Dimensions in mm

### SS CHIPBOARD SCREW (DIN - 7505)

**Diameter Range** : 3MM To 6MM  
**Length** : 9.5MM To 100MM  
**Threads Type** : (AB) Type  
**Material** : Stainless Steel and also as per customer requirements  
 Standards: DIN, ISO

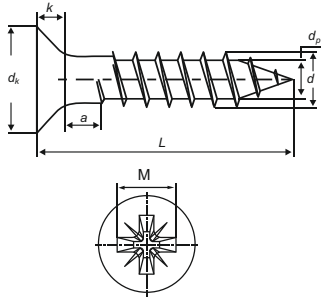

Screw thread (d)		3	3.5	4	4.5	5	6
d	max	3.0	3.50	4.0	4.50	5.0	6.0
	min	2.75	3.20	3.70	4.20	4.70	5.70
p	Pitch(+/-10%)	1.35	1.60	1.80	2.0	2.20	2.60
a	max	2.35	2.60	2.80	3.0	3.20	3.60
dk	max=nominal	6.0	7.0	8.0	9.0	10.0	12.0
	min	5.7	6.64	7.64	8.64	9.64	11.57
k		1.8	2.0	2.35	2.55	2.85	3.35
dp	max=nominal	1.9	2.15	2.50	2.70	3	3.70
	min	1.5	1.67	2.02	2.22	2.52	3.22
Socket No.		1	2	2	2	2	3
M		3.0	4.0	4.40	4.80	5.30	6.60

\*All Dimensions in mm



### ALLEN CSK MACHINE SCREW (DIN - 7991)

**Diameter Range** : 3MM To 6MM  
**Length** : 6MM To 100MM  
**Threads Type** : MM, UNC, UNF, BSW  
**Material** : Stainless Steel and also as per customer requirements  
 Standards: DIN, ISO

## MOTSON FASTENERS

### CSK PHILIPS MACHINE SCREW (DIN-965)

**Diameter Range** : 3MM to 6MM dia  
**Length** : 3MM to 100MM  
**Threads Type** : BSW, MM, UNC, UNF  
**Material** : Stainless Steel and also as per customer requirements  
 Standards: DIN, ISO

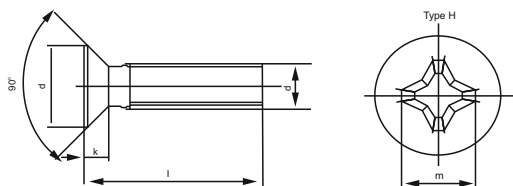

Thred size [d]	M3	[M3.5]	M4	M5	M6	
Pitch	0.5	0.6	0.7	0.8	1	
max	5.6	6.5	7.5	9.2	11	
	5.3	6.14	7.14	8.84	10.57	
k max	1.65	1.93	2.2	2.5	3	
Cross recess No.	2				3	
M~	2.9	3.9	4.4	4.6	6.6	
Penetration Typw H depth	min	1.5	1.4	1.4	2.1	2.8
	max	1.8	1.9	1.9	2.6	3.3

\*All Dimensions in mm

### PAN PHILIPS MACHINE SCREW (DIN-7985)

**Diameter Range** : 3MM to 6MM dia  
**Length** : 6MM to 100MM  
**Threads Type** : BSW MM UNC UNF  
**Material** : Stainless Steel and also as per customer requirements  
 Standards: DIN, ISO

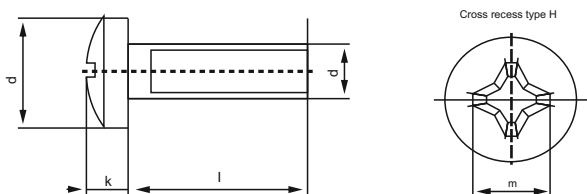

Thred size [d]	M3	[M3.5]	M4	M5	M6	
Pitch	0.5	0.6	0.7	0.8	1	
d max	6	7	8	10	12	
	5.7	6.64	7.64	9.64	11.57	
k max	2.52	2.82	3.25	3.95	4.75	
	2.28	2.58	2.95	3.65	4.75	
Cross recess No.	2			3	4	
M~	3.1	4.2	4.6	5.3	6.8	
Penetration Typw H depth	min	1.7	1.74	2.04	2.77	3.03
	max	2	2.24	2.54	3.27	3.53

\*All Dimensions in mm

### OVAL HEAD MACHINE SCREW (DIN-966)

**Diameter Range** : 3MM to 6MM dia  
**Length** : 6MM to 100MM  
**Threads Type** : MM, UNC, UNF, BSW  
**Material** : Stainless Steel and also as per customer requirements  
 Standards: DIN, ISO



## MOTSON FASTENERS

### HEXALOBULAR SOCKET COUNTERSUNK FLAT HEAD SCREW (ISO-14581)



**Diameter Range** : 3MM to 6MM  
**Length** : 6MM to 100MM  
**Threads Type** : MM, UNC, UNF, BSW  
**Material** : Stainless Steel and also as per customer requirements  
Standards : DIN, ISO



### HEXALOBULAR SOCKET PAN HEAD SCREW (ISO-14583)

**Diameter Range** : 3MM to 6MM  
**Length** : 6MM to 100MM  
**Threads Type** : MM, UNC, UNF, BSW  
**Material** : Stainless Steel and also as per customer requirements  
Standards : DIN, ISO



### HEXALOBULAR SOCKET COUNTERSUNK HEAD SCREW (ISO-14584)

**Diameter Range** : 3MM to 6MM  
**Length** : 6MM to 100MM  
**Threads Type** : MM, UNC, UNF, BSW  
**Material** : Stainless Steel and also as per customer requirements  
Standards : DIN, ISO

### HEXALOBULAR SOCKET PAN HEAD TAPPING SCREW (ISO-14585)

**Diameter Range** : 2.9# To 6.3#  
**Length** : 6.5MM to 100MM  
**Threads Type** : (AB) Type AND (B) Type  
**Material** : Stainless Steel and also as per customer requirements  
Standards : DIN, ISO



### HEXALOBULAR SOCKET COUNTERSUNK HEAD TAPPING SCREW (ISO-14586)

**Diameter Range** : 2.9# To 6.3#  
**Length** : 6.5MM to 100MM  
**Threads Type** : (AB) Type AND (B) Type  
**Material** : Stainless Steel and also as per customer requirements  
Standards : DIN, ISO



### HEXALOBULAR SOCKET RAISED COUNTERSUNK HEAD TAPPING SCREW (ISO-14587)

**Diameter Range** : 2.9# To 6.3#  
**Length** : 6.5MM to 100MM  
**Threads Type** : (AB) Type AND (B) Type  
**Material** : Stainless Steel and also as per customer requirements  
Standards : DIN, ISO



### BUTTON HEAD SOCKET MACHINE SCREW (ISO-7380)

**Diameter Range** : 3MM to 6MM  
**Length** : 6MM to 100MM  
**Threads Type** : MM, UNC, UNF, BSW  
**Material** : Stainless Steel and also as per customer requirements  
Standards : DIN, ISO



## MOTSON FASTENERS

Phillips drive for more positive & no cam out



Sharp Thread for Faster Penetration and extra holding power



Point allows easy to start penetrating

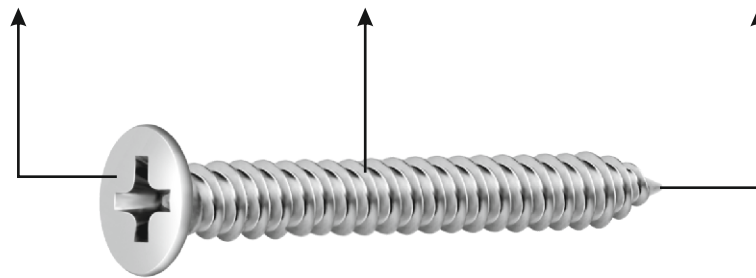

**MFG. BY : STAINLESS STEEL FASTENERS**

Phase - 1, Plot No-53 To 62/8, Ambawadi GIDC,  
Wadhwan city, Surendranagar-363005 (gujarat) INDIA  
Phone : 02752 243222, ● Mo. : +91 96242 92246 ● +91 99094 48046  
E-mail : motsonsteelind@gmail.com  
www.motsonfasteners.com